

BULLETIN

THE AMERICAN INTERPLANETARY SOCIETY

113 West 42nd Street, New York, N.Y.

David Lasser, President

Clyde J. Fitch, Editor.

No. 10.

New York

June-July - 1931

CONTENTS

Piccard Balloon Makes Successful Stratosphere Flight	1
Successful Flights Made With Rocket Driven Motor	1
Patent For Rocket Airplane Issued to Goddard	2
Prize Awarded For Study Of Rocket's Strength	3
Dr. Lyon Selects Desert For Rocket Experiments	3
Rockets May Be Employed To Study Terrestrial Magnetism.....	3
Rockets Featured In Recent Publications.....	4
Plans Rocket To Lift Man Fifty Miles	5
"Across The Atlantic In A Rocket Plane", Abstract of Report by Harold A. Danne	5
A Letter From Dr. Goddard	9

* * * * *

Piccard Balloon Makes Successful Stratosphere Flight

Hermetically sealed in an aluminum ball containing several hours supply of oxygen, Professor Auguste Piccard, professor of physics of the University of Brussels, and Charles Kipfer, his assistant, rose to an altitude of 52,000 feet, on a scientific mission into the stratosphere. The balloon was released near Augsburg, Germany, on May 27, 1931.

This is the highest altitude ever reached by man. Lieutenant Apollo Soucek, of the United States Navy, flew a land plane to a height of 43,158 feet, about eight miles, last June. Sounding balloons have been sent up sixteen miles.

Professor Piccard's balloon is the largest ever built. It has a diameter of 100 feet and holds 500,000 cubic feet of hydrogen. It contained 95,000 feet at the start, which expanded to full capacity at an altitude of about 40,000 feet.

The aluminum ball was painted half black and half white. By means of a small electric motor, either side could be turned toward the sun, so that heat could be reflected or absorbed, as desired.

Successful Flights Made With Rocket Driven Glider

Perhaps the first successful rocket-propelled glider flight in this country was made on June 4, 1931, by William G. Swan, 29 year old resort stunt flier, at Atlantic City, N. J.

The glider, which weighs 200 pounds, was equipped with ten rockets. It was launched by a ground crew in the usual manner, after which Swan closed an electric switch and ignited the first rocket. The craft rose bumpily to an altitude of 100 feet and soared for 1000 feet, under the propelling power of the one rocket. The other nine were not ignited for this first flight.

(2)

On the second flight, June 5, the full force of twelve rockets was applied. The glider rose to a height of 200 feet and remained in the air for eight minutes, landing gently after the rocket power was expended. The glider will be equipped with pontoons, and flights will be made throughout the summer.

"The first flight of an airplane propelled by rockets was accomplished by Fritz von Opel, German inventor, at Frankfort, Germany, on Sept. 30, 1929. The machine which he used was a single-winged glider, in which he was aloft for a minute and a quarter, covering a distance of about a mile and a quarter at an average altitude of 49 feet. The glider was wrecked in landing.

Successful tests of a tailless rocket-plane were also made by Gottfried Espenlaub, glider and airplane builder, at the Lohausen Duesseldorf flying field in Germany during April, 1930. The craft was badly damaged in a crash during the tests."

Patent For Rocket Airplane Issued To Goddard

Professor Robert H. Goddard, noted rocket experimenter, has obtained a patent, No. 1,809,271, on June 9, 1931 on a rocket driven airplane. The application was in the Patent Office for about two years.

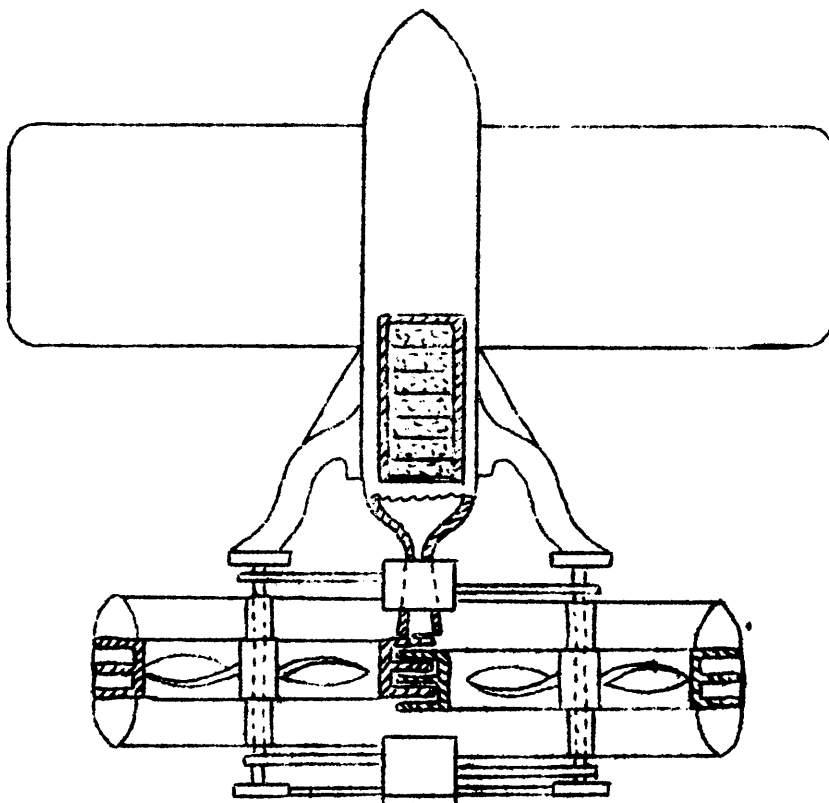

GODDARD'S ROCKET AIRPLANE

The principle disclosed in the specifications utilizes the exhaust fumes of the rocket motor to drive a turbine wheel, as in a gas turbine, which in turn drives the propellers for flight through the denser layers of the atmosphere. As the plane reaches the rarefied strata of the upper atmosphere, the power of the exhaust gases acts directly as a rocket without the use of propellers. The following is one of the ten patent claims allowed:

"In an aircraft, the combination with a source of energy and means for creating a blast of gas traveling at high velocity from said source of energy, of turbine wheels rotatable on axes disposed on opposite sides of said gas blast with propelling vanes on both of said wheels disposed in the path of said gas and a series of air propeller blades disposed within the vanes of each wheel. "

Prize Awarded For Study Of Rocket's Strength

The Astronomical Society of France announced on June 10 the awarding of the yearly Rep-Hirsch prize for the best scientific ideas to promote interplanetary navigation, to Pierre Montagne, of the French School of Mines.

M. Montagne worked out in his laboratory a system for the precise calculation of the driving force of combustible fluids, which might be used to propel rocket vehicles. The system enables scientists to estimate the distance a rocket ship or vehicle could travel beyond the gravity zone and air shell enveloping the earth, and makes costly experiments and tests unnecessary.

Dr. Lyon Selects Desert For Rocket Experiments

A rocket will soon be fired from a desert stretch 200 kilometers south of Tripoli, by Dr. Darwin O. Lyon of New York, for further investigations of the nature of the upper atmosphere and study of the cosmic rays. The rocket is expected to reach an altitude of 12,000 meters. The rocket will contain various delicate scientific instruments, which will be brought safely to ground by means of a parachute.

Further tests are planned with a rocket which will fly 16,000 meters and carry two birds and two mice for studying their reactions under the influence of the cosmic rays.

Rockets May Be Employed To Study Terrestrial Magnetism

Writing in the July Scientific Monthly, J. A. Fleming, acting director of the Department of Terrestrial Magnetism, Carnegie Institute of Washington, gives some interesting data on terrestrial magnetism and the possible use of rockets for making further investigations. The following is, in part, Mr. Fleming's article, which was also broadcast over the Columbia System:

"Observations during the last century have revealed the close relation between sun-spot activity and disturbances of the earth's magnetism. As the earth revolves about the sun the maximum changes in magnetic, earth-current, and polar-light activity occur during the equinoctial months of March and September, and the minimum during

(4)

the solstitial months of June and December.

Magnetic observations have added materially to our knowledge of the earth's interior, particularly to some of the geological features of the earth's crust. Thus the secular variation suggests changes within the crust, indicating an interior more mobile than the exterior layers. These studies give us additional information regarding the high atmosphere above the earth and, in particular, regarding the Kennelly-Heaviside layer. Observations of fluctuations in height of this layer show its fundamental importance in terrestrial magnetism and in radio transmission.

The penetrating radiation or cosmic rays from space may be the connecting link to tie together in a satisfactory theory the present indications of the sun and of the variable electric currents in our atmosphere and within our globe as the ultimate causes of the earth's magnetism and its variations. Therefore, laboratory experiments have been conducted for some years by the Department of Terrestrial Magnetism of the Carnegie Institution of Washington in the study of the structure of the atom and its magnetic properties through the artificial production of high-voltage radiations. Another connecting link may be in possible modifications in the physical properties in the higher atmosphere from those in lower altitudes of which we know. Researches in this connection await development of rockets capable of reaching heights from 25 to 50 miles or even more. Recent tests indicate early realization of technique to accomplish this.

Rockets Featured In Recent Publications

Advanced information on rockets appears from time to time in the various popular and scientific publications. One of the most complete and concise articles on the subject entitled "Harnessing Giant Rockets" is that of G. Edward Pendray, vice-president of the Society, which appeared in the August issue of Popular Science.

The August issue of Modern Mechanics also contains an interesting article entitled "Exploring The Moon By Rocket Ship", by Robert Esnault-Pelterie, as told to Alfred Albelli.

Plans Rocket To Lift Man Fifty Miles

Professor A. M. Low, English Scientist, recently announced that he has been approached to construct a rocket to carry a person fifty miles into the air.

This man-carrying rocket is to be complete with oxygen equipment and a parachute for making a safe landing. Professor Low states that the project is theoretically feasible, and that a rocket would be the best means for attaining the great height of fifty miles, because a balloon, such as the type employed by Professor Piccard, to ascend that far would have to be colossal in size. (As a matter of fact, no balloon no matter how colossal, could attain such a height -- Editor)

* * * * *

ACROSS THE ATLANTIC IN A ROCKET PLANE

(Abstract of a report by Harold A. Danne, Aeronautic Engineer, to the American Interplanetary Society at meeting of May 15, 1931 as part of Research Program of the Society.)

I have been asked to speak on the application of the rocket motor to transatlantic flying. To succeed in such an enterprise, we must construct an airplane of suitable design and features, a motor operated on the rocket principle and above all, and under human control.

We must consider, first the best type of plane for the purpose. Since four-fifths of the earth's surface is water and one-fifth land, for the sake of safety of the crew, we shall have to choose a type that will float on water at any time. An amphibian plane therefore is the most desirable type. Amphibian planes have a technique of design and construction all their own. Our ship then must be large enough to comply with the chief requirements of Marine architecture. For this reason our ship should be at least 170 feet long and 30 feet in diameter at the widest part and as near perfectly streamlined as we can make it.

Let us consider other features such a plane must have on such a trip to be a complete success. It must be watertight, as we are possibly to land, cruise and takeoff from water. It must be airtight, as we are to fly where air conditions are abnormal. It must be temperature proof, as we are to fly through very low temperatures and at speeds that will develop high temperatures on the skin of the plane.

As such a plane will be a virtual flying laboratory on the first trip, conditions inside must be similar in all respects to the atmosphere and conditions on the earth.

It will be necessary to provide a heat-cold insulated, sealed fuselage, which will contain men, instruments and possibly a power plant in a normal atmosphere to which these men, instruments and motors are accustomed and adjusted. The air conditioning machine might be similar to those now in use for small buildings, flats, and apartments.

Folding wings and wheels for landing on the ground will also be installed on our plane, similar to those now used in various makes of planes in service all over the United States.

(6)

As the first flight is to be of a purely scientific nature we must have a large instrument room in our plane. The front part of the plane is best for this purpose, but it must be protected by double walls against heat, cold, moisture, dust and outside influences of all kinds, except where needed.

High altitude flying has proven that at about 36,000 feet the temperature varies from 40 to 75 degrees below zero. In some cases the temperature tends to rise and not to fall as the ship goes up further. This seems to indicate that the maximum cold we have to contemplate will be not more than 75 degrees below zero and that the temperature of the stratosphere does not become indefinitely low, but remains at or about -75.

Our plane must be so constructed that these temperature differences will not impair the life, health or working ability of the crew, or instruments or hinder the successful return of these to the earth. Therefore the sealed fuselage is important. With modern welding this will be easy and it will be only with the openings in the outer skin of the plane that we will have difficulty.

Max Valier projected a flight from Berlin to New York in about one hour. He planned to take the DO-X or a similar flying boat and equip it with a rocket motor. He estimated the resulting speed at over 3000 miles per hour at an altitude of 50,000 feet. Such a speed, would in my opinion need a special ship, as the framework and wings of the DO-X would probably collapse under the enormous pull and thrust stresses of driving the ship at such a speed, even through the thin air of upper space.

Furthermore, a flying boat, such as the DO-X, that could not safely land on the ground would be most undesirable..

The effects of the low temperatures and pressures at high altitudes on the liquid or compressed gases used in the modern rocket motored ship are highly important.

The reduced pressure increases the losses by evaporation and also increases the internal pressure on the containers or tanks. Also, according to the latest rocket technique, it increases the power of the rocket motor as the pressure against which the explosion operates is reduced proportionately.

Under all conditions we must have and keep control of our rocket plane. The stronger and greater the power we have, the more refined and sure must be the methods of control. We therefore need special devices to keep us headed at all times in the right course. A device similar to gun sights was found necessary in racing automobiles at full speed might be used. We will have become then a modified form of big gun projectile. We propose to try such sights as are used in aerial machine guns, which automatically allow for cross winds and speed and other factors that would otherwise drive us off our course.

In this connection, it is well to consider in a broad general way the effects of certain facts aviators have discovered about the winds of the upper altitudes.

It has always been a theory as the earth spins on its axis toward the East, the air enveloping the earth lags behind it.

But here is a curious new fact. Flyers have found that the winds show an invariable tendency, not easterly, as might be supposed, under the above reasoning, but more and more westerly relative to the ground. The higher we fly, the more the winds shift to the west.

As a practical result, the average time of flight eastward, other things being equal, over a large number of flights, is shorter than the average westerly flight. Especially is this observed in heavily loaded commercial planes.

Aviators are therefore inclined to question the assertion that the air envelope round the earth lags and they consider that it probably travels much faster than the earth, the higher you fly, until it becomes due west and travels at a much faster speed than the earth.

A flight in our rocket plane such as we are speaking of will tend to solve many of these problems by supplying to us additional facts observed on the spot at extreme heights.

The Route

The route of this trip is to be from or near New York City, (Floyd Bennett Field in all probability) to or near Paris, Le Bourget Field preferably, and the distance will be about 3000 miles.

The start and glide to the landing will occupy together not less than half an hour and the main part of the journey at an elevation of 50,000 feet will take about one hour, flying at 3000 miles per hour, as we expect to.

To travel the distance safely, we shall have to take care that the acceleration is not too great for the safety of the crew and cargo and also that the deceleration is done at a safe rate.

When an amphibian rocket plane, as we are planning, has reached the speed of 200 miles per hour or over, it is desirable to reduce the head resistance or "Lag", as Aeronautic engineers call, it by folding the wings.

Correspondingly, when the ship has decreased its speed to 200 miles per hour or less it is desirable, even necessary, to unfold the wings if we are to make a landing or if we desire to remain aloft.

It will need much ingenuity to design the wings in so large a ship as we must have especially to design them so that they can be unfolded while flying and against considerable air pressure. A telescopic wing would no doubt serve this purpose.

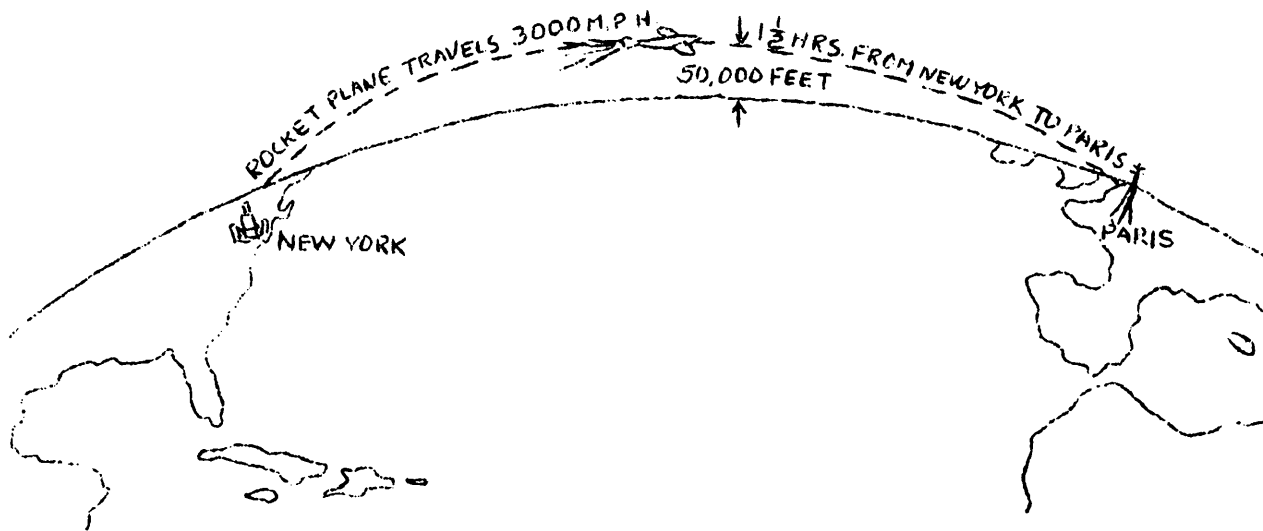

(8)

With the wings folded, we will have to rely on the surface of the fuselage to keep us aloft and enable us to ride the air rushing by at such enormous speeds.

Using, as we will, mixed hydrocarbons and oxygen, the smoke will not be great, but the heat will be enormous and will have to be gotten rid of by steam cooling jackets or similar devices. The low temperatures of the high altitude is expected to assist us in this problem but the few minutes before we gain these altitudes are a special problem in themselves.

When we reach the required elevation we will have almost ideal conditions for flying. A tail wind, no moisture to form and freeze on the plane and a clear view for hundreds of miles.

The climbing angle to attain this elevation would be small at first - say ten degrees until the acceleration caused by the push of our powerful motors becomes effective and then we can increase the angle to forty-five degrees or even more if the crew and cargo can stand the unnatural position.

Navigation

The question of methods of navigation is of primary importance and the time of starting especially on our first or trial trip is a serious one.

Inasmuch as the stars are the greatest and best guides for all navigation and, especially for flying at high altitudes, I am of the opinion that night would be the best time for the first flight of our rocket plane.

In ordinary night flying, we first set the course on maps and by other data and then go out in the plane and set the ship on this course on or near the field - that is at a low altitude above the field.

We then observe the relation of a suitable fixed star like the North star to the fuselage marking. By maintaining this relative position during the whole flight we will be sure of not deviating from the course planned.

It would be best for these reasons to make the first flight by night so as to arrive in Europe at dawn or shortly after. Using sights on our fuselage that allow for wind drift, we can train them on a fixed star and fly in a nearly straight line, even allowing for the curvature of the earth.

Such sights are used on aerial guns. They include a wind vane foresight and a ring backsight and would be very useful if adapted to such a fast plane as we will fly on this trip. These sights give a high degree of accuracy in aerial gunnery.

The use of such means of accurate navigation is essential to avoid constant taking of latitude and longitude, nevertheless it will be necessary to have a crew skilled in this technique.

The Trip

At the takeoff from land we have a plane loaded to capacity with fuel, machinery and crew. Flying experience under the conditions indicates that such a takeoff be made carefully from rest and gradually, that is at a very small angle from the horizontal, as little as ten degrees at first.

As the fuel is consumed and the speed is accelerated the plane becomes more able to sustain the load and the speed and angle can be increased until an angle of forty-five degrees is reached.

Beyond this angle it is not desirable to go, under such conditions, and no designer will allow the pilot of the plane to "put her nose up" as they say more than this. The unnatural position of the ship, might cause such twists on the framework and other stresses and strains as to cause collapse.

The temperature of the fuselage skin has to be watched and if too high the speed reduced. These precautions and many more will be thoroughly understood by the trained crew. Automatic appliances will be used wherever practical, but owing to our uncertainty as to the exact conditions at these altitudes the best human control and ability should be used and available at all times. When unusual things happen automatic rockets and such other automatic devices are liable to go wrong and destroy all the results of the most careful planning and work.

At the end of our trip we will find it necessary to unfold our wings again, reduce our speed and glide down at the required angle until we are over Paris and into the region of clouds, irregular winds and other undesirable earth conditions.

There we become a slow moving plane again and fly to Le Bourget Field with our precious cargo of records of the upper atmosphere.

* * * * *

A LETTER FROM DR. GODDARD

Editor, Bulletin of the American Interplanetary Society:

I have received a letter from Dr. Robert H. Goddard, in which he settles once and for all the question of his famous rocket shot of July 17, 1929. With Dr. Goddard's authority we can now state that the first continuously-firing liquid fuel rocket ever to be shot was sent on that date near Worcester, Mass., by Dr. Goddard. This is a point that has been much debated both in this country and abroad, and though Dr. Goddard wrote to correct a statement of mine published in the Bulletin of May, 1931, I am glad that the matter has been settled finally in such an unequivocal fashion.

In justice to Dr. Goddard I should like to ask you to publish his letter in the Bulletin, both to correct my statement concerning his July 17 shot and to establish among the readers of the Bulletin his claim to the first liquid-fuel rocket flight. I am sending the letter herewith.

Yours sincerely,

(signed) G. Edward Pendray

Mr. G. Edward Pendray
American Interplanetary Society
113 West 42nd Street,
New York City.

My dear Mr. Pendray:

The No. 9 issue of the Bulletin of the American Interplanetary Society has recently come to my attention, in which there is an abstract of your report on

the German rockets which contains the following statements: "Goddard...is said to have sent up his 1929 rocket by a series of explosions, instead of continuous fire...in any case it is clearly not the solution to the problem." Also, "If this performance (the proposed III Mirak) seems small and unimportant, remember that a successful flight of any kind has never been made with continuously burning liquid fuel."

The actual facts are as follows: The 1929 flight referred to was obtained with a rocket using liquid hydrocarbons and liquid oxygen, with continuous combustion. I mentioned this to the newspapers at the time, and Dr. Charles G. Abbot, Secretary of the Smithsonian Institution, also mentioned that it was continuous combustion. This point has been brought to public notice at various times since; for example, on page 10 of the Report of the Secretary of the Smithsonian Institution for June, 1930, there occurs the following statements: "After much experimenting with a rocket equipped with a device for feeding small charges of high explosive, Doctor Goddard turned finally to the scheme of a steady combustion of hydrocarbon in liquid oxygen.... It may be said that on July 17, 1929, a trial of the liquid-propelled rocket was made at Worcester, Mass., the device functioning satisfactorily as regards the flow of liquid, the ascent of the rocket, and its rapid motion in air." Incidentally, this rocket was equipped with instruments which were recovered intact. It might be well to add that my work with rocket motors, using liquids and continuous combustion, dates back to 1920.

The writer has, incidentally, been given credit for the first successful liquid-propellant rocket flight by a number of writers; Kaempffert in "Rocket Ships" in the October 1930 Forum says: "He (Goddard) is the only one who has successfully propelled rockets with liquid gases."

Considering that the matter of a liquid propellant rocket flight in which continuous combustion is used is of such obvious importance, I feel that, in the interest of accuracy, this point should be corrected in the next issue of the Bulletin of the Society.

The article in the Bulletin also speaks of my reticence in giving my results to the public. It happens, as I have explained to Mr. Lasser, that so many of my ideas and suggestions have been copied abroad without the acknowledgement usual in scientific circles that I have been forced to take this attitude. Further, I do not think it desirable to publish results of the long series of experiments I have undertaken until I feel that I have made a significant further contribution to the problem.

Very truly yours,

(signed) R. H. Goddard

Meetings of the New York members of the American Interplanetary Society are held on the first and third Fridays of each month at the American Museum of Natural History, 77th Street and Central Park West. Persons interested in the aims of the Society are invited to attend and to write to the secretary, Nathan Schachner, 113 West 42nd Street, New York City, for information about the various classes of membership, including active, associate and special, which are open to men and women who possess the necessary qualifications.